

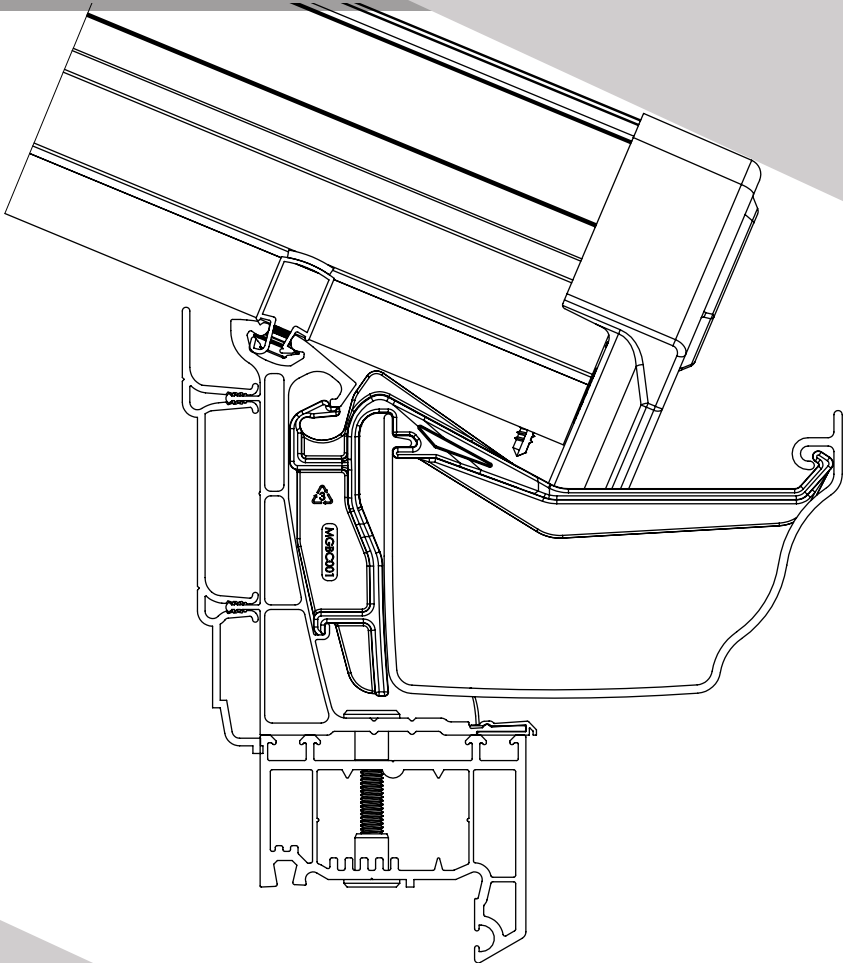

WENDLAND

ROOF SOLUTIONS



Glass Roof Technical Guide

August 2024

Wendland has been a leader in the conservatory industry since 1995 and the Wendland glass roof system is known for its quality and strength. Wendland designs, manufactures and supplies a wide range of products for the conservatory and home extension market, including the Wendland glass roof, solid and tiled roof products, lantern products and product upgrades such as the internal pelmet and gutter cover.

For assistance with roof design or specification please contact the Technical Support Team on 01200 452918 or email techsupport@wendland.uk.com

CONTENTS

Technical Overview	3
Ridge system	4
Glazing bars, Crestings and Tie Bars	5
Re-inforced glazing bars & Jack Rafters	6
Eaves	7-8
Box Gutters	9
Gable beam	10
Valley & Ventilation	11
Conservaflash	12
Glazing options	13
Colours and finishes	14-15
Internal Pelmet & Gutter Cover	16



Accreditations



Within some projects there are critical structural elements such as 'goal post' beams and supports which are used around large bi folding doors or to support box gutters where a glazed roof meets a wall or other roof. These crucial structural components now have to be CE Marked and Wendland's manufactured items have this accreditation.

Wendland operates a quality system which means it is independently assessed every quarter by BSI. This means an audit by trained inspectors to ensure we design, manufacture and supply in accordance with ISO 9001:2008 quality standard.

NOT COVERED IN THIS GUIDE: Lantern, Flat Skylight, Livinroof and Ultrarof

WENDLAND GLASS ROOF

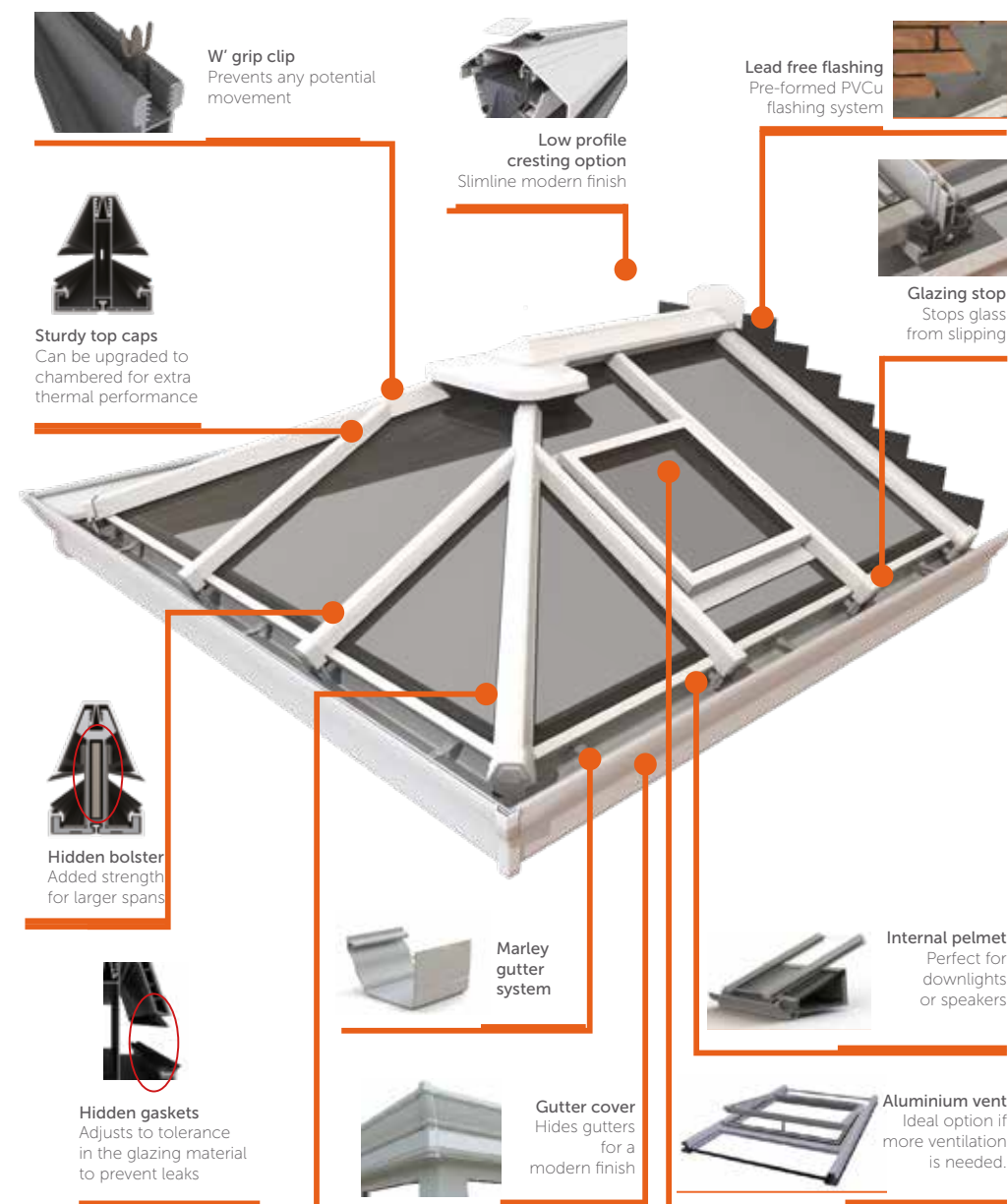

FULL RIDGES

The full ridge features and benefits are:

Pitches from 15-40°

- 25/32mm glazing capabilities
- Uses current dual and single fixing blocks
- PVCu blanking piece available for ridge cap
- Glazing fascia trim/seal available at ridge

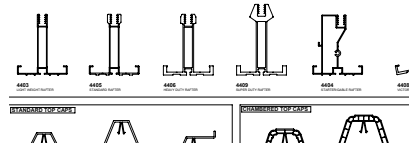

LEAN TO RIDGE

The lean to ridge features and benefits are

- Pitches from 2.5-30°
- 25/32mm glazing capabilities
- Dual and single fixing blocks
- Glazing fascia trim/seal available at ridge.
- Current ridge end caps used.

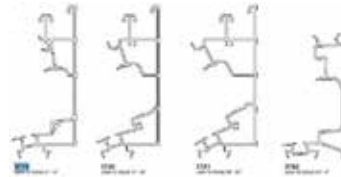

RIDGE / HALF RIDGE SPIDERS

The Wendland "spider" is quick and easy to fit

- Pre-drilled for a perfect fit
- Two sizes (large and small)
- Easy to fabricate as bars can be square cut



RIDGE / HALF RIDGE ASSEMBLY

The Wendland MK5 ridge has a pitch capability of 15° - 40° spread over three different ridge types. Shown below is an assembly highlighting the main parts that make up a standard ridge.

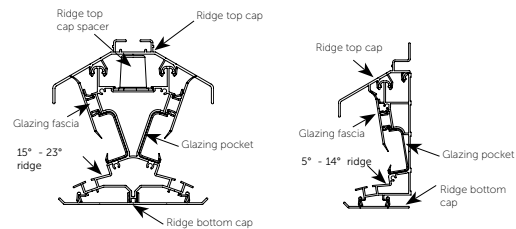

RIDGE SPIDER ASSEMBLY

The spider is the point at which the hip and intermediate bars meet the crown point and are fixed. This is then clad with a crown cap and bottom cap then secured using a retaining boss.

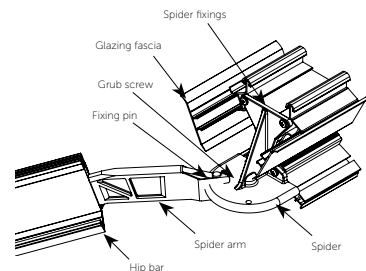

RAFTERS, HIPS & GABLE ASSEMBLY

The Wendland roof has a suite of glazing bars that range in strength and capabilities in order to achieve the desired roof design. Below shows some of the suite and the parts that make up the glazing bars.

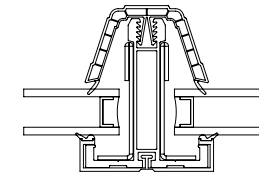

Heavy Duty Rafter

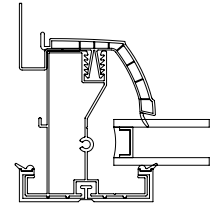

Starter assembly

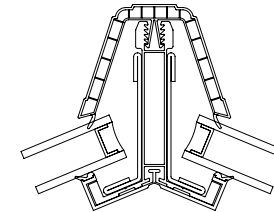

Edwardian hip

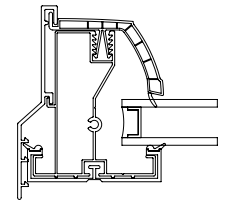

Gable assembly

CRESTINGS AND FINIALS

A choice of two finials and crestings allows you to personalise the conservatory.

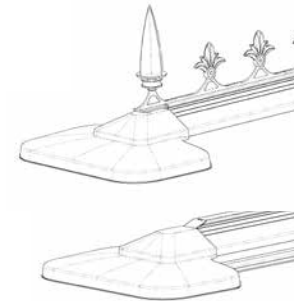

Technical Specification

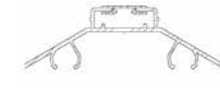

Cresting Blank - slides into ridge track



Cresting Fixing Detail - Cresting slides into ridge track

TIE BARS

Structurally, tie bars are required to resist downward forces like snow - they prevent the ridge deflecting and the frames rolling outwards. If specified on a conservatory, they **must** be fitted. There are two main types of tie bar, 3 way and 5 way.

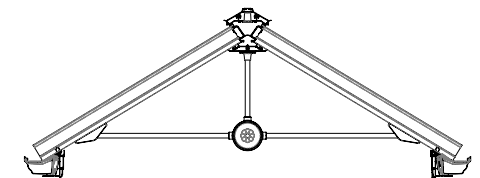

HALF RIDGE CROWN CAP

- Available in both Edwardian and Victorian
- The smaller cap looks much better
- Suits the small spider arm only*
- Available in the full colour suite
- *Can be used on angles between the bars that are above 20°



Victorian ridge end



Edwardian ridge end

RE - INFORCED BARS GLAZING BARS

Additional structural performance is needed in certain circumstances. Standard glazing bars can have steel reinforcement inserts.

Heavy duty bar Super duty bar Victorian hip bar Edwardian hip bar



BOLSTER GLAZING BARS

A bolster is used when the conservatory span is too great for either the standard or reinforced glazing bar. This offers additional spanning performance of the glazing bar. The PVCu bolster cladding finishes shy of the ridge / wall plate and eaves and is finished with a PVCu end cap.

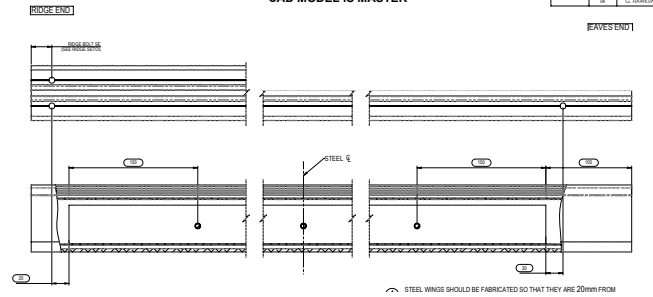
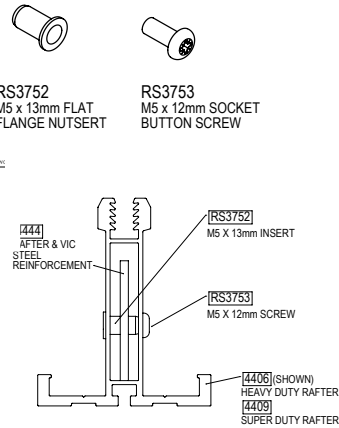

BOLSTER END CAP

- Available for Transom, Edwardian and Victorian.
- Available in the full colour suite
- End cap is sealed in place and supported with location tabs



JACK RAFTER FIXING BRACKETS

Steel pivoting brackets are factory fitted to the jack rafters. These are bolted to the hip on site through factory positioned, pre drilled holes ensuring a robust connection.



W GRIP CLIP

A natural characteristic of a roof is that they expand and contract by differing amounts. The W grip clip controls the point at which movement occurs to maintain the critical weather tight seal at the upslope (ridge) end to move at the bottom of the roof, in the gutter zone.



Supplied as standard prevent any potential movement. The W Grip clip grabs the barbs of the top cap. Jack rafters are also fitted W Grip clip. The glazing bars are prepped at the ridge end of the slope by the factory insertion of a hole through the teeth in the aluminium bar into which is inserted a clip.

STANDARD EAVES BEAM

The standard eaves beam is a high strength one piece aluminium extrusion. It can accommodate pitches between 5° - 41°. The eaves beam is compatible with the upgrades available e.g. internal pelmet and gutter cover

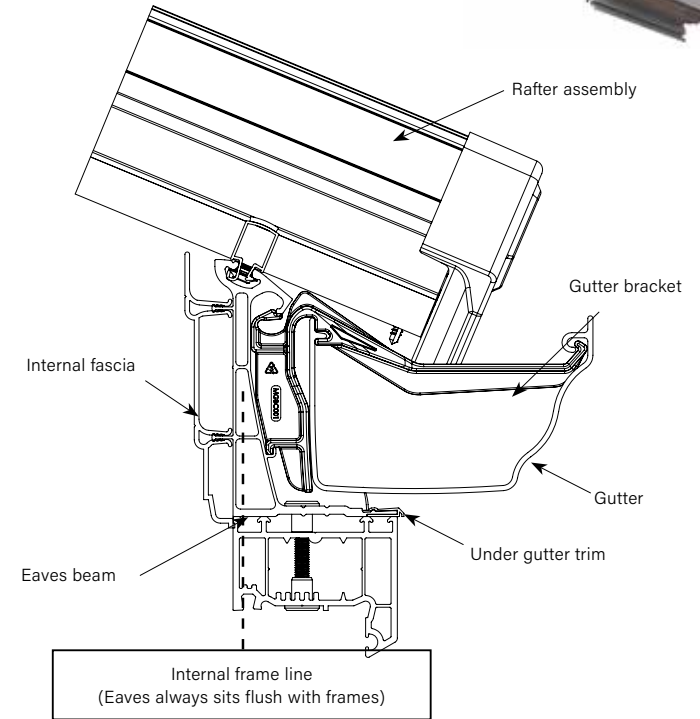

BI FOLD SUPPORT BEAM & EAVES SUPER BOLSTER

Bi-fold support beam which mounts to the underside of the eaves. Eaves super bolster which mounts to the inside of the eaves beam.

- The bi-fold support beam and eaves super bolster profiles can be used separately to bolster the eaves or combined to further increase the spanning capability.
- The bolster sections only need to be specified on the elevation where the larger opening is required.
- The bi-fold support beam is 70mm tall and runs between corner posts.
- The eaves super bolster support beam is 134mm tall.
- PVCu claddings on internal and external fascia.

On the elevations which do not require the spanning capability, either the frame height can be adjusted, or a standard frame add on or corner post profile can be used to pack the frames under the eaves.

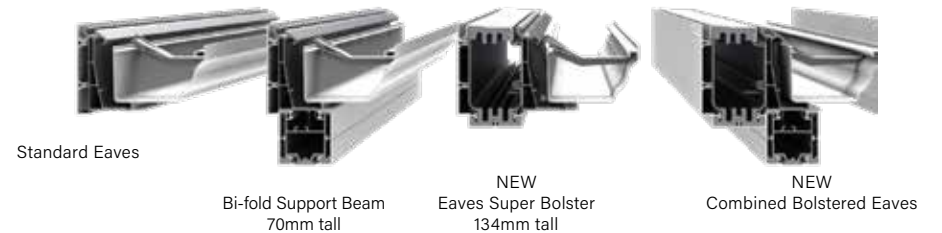

LOW PITCH EAVES

If the glass roof is required between 2.5° - 5° pitch, then in place of the standard glass eaves beam it uses one that sits lower. It features a simple 'flowline' gutter too in place of the standard 'ogee' gutter.

TECHNICAL SPECIFICATION LOW PITCH EAVES BEAM

- For use between 2.5° to 5° - can be specified up to 10°
- Structural firrings at 2.5° and 5° are available
- Suitable for raked frames too
- Overhang of glass on low pitches below 10° is 105mm
- Applicable to both the low pitch eaves and standard eaves (low pitch eaves shown).



THESE ITEMS RELATE SPECIFICALLY TO THE LOW PITCH:

STRUCTURAL FIRTINGS

Wendland have gone one step further with these ready assembled interlocking profiles that not only fill the 'hole' between the side frames and the roof but which add substantial support to the whole structure particularly when doors are in the end elevations.



Steel reinforcement to each side is 'stage two'.

Aluminium box section is 'stage one' reinforcing.

- Available at 2.5° and 5° pitch in 3045mm and 4045mm lengths - these need to be cut to length on site.*
- The firrings consist of a series of inter connected/locking PVCu profiles that are supplied pre-fabricated.
- Firrings are supplied in different 'conditions' to suit various projections and applications.
- The 'flowline' guttering can be clipped to the furring allowing the guttering to run along the front and sides of the conservatory. This can save the need for a soakaway as the guttering can be routed back to the house and rain water dispersed down the dwelling's existing fall pipes.

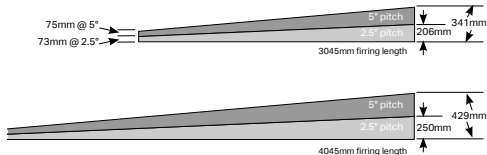

BOX GUTTER SPECIFICATION

When there is insufficient height under the bungalow soffit it may necessary to utilise a box gutter with an extended leg and flange to gain extra height.

In these situations, the box gutter MUST be supported by brick piers or gallows brackets.

Always speak to the Technical Support Team about the correct design/specification in this area - the box gutter and structural gallows bracket are priced on a project by project basis.



BOX GUTTERS

When a conservatory roof slopes backwards towards the existing building a box gutter is required. There are 165mm, 265mm and raised back. The box gutters are pre-fabricated and fast to fit.



Raised Back box gutter - custom design



265mm Standard box gutter



165mm box gutter

Gutter Strap Assembly

Box gutter adapter which comes with a measured 'shot' of Gutterbond sealant

REINFORCED BOX GUTTER

- A factory insulated reinforced box gutter that enables a 6M span with 265mm box gutter
- Must be supported either end by hupl, brick wall, or aluminium post *
- Reduces / eliminates the need for gallows brackets on bungalows
- Breaks in the I beam allow for water flow and fixing access & point at the image
- The maximum length of box gutter is 6m, to suit internal frame size of 5860mm.
- The box gutter can be jointed every 5.8m. Joints must be supported at each location and specified when ordering
- Whole assembly will be pre-welded
- Can be used on all Glass Roof and Livinroof
- The weight of the beam is 13kg/m, therefore lifting should be considered.

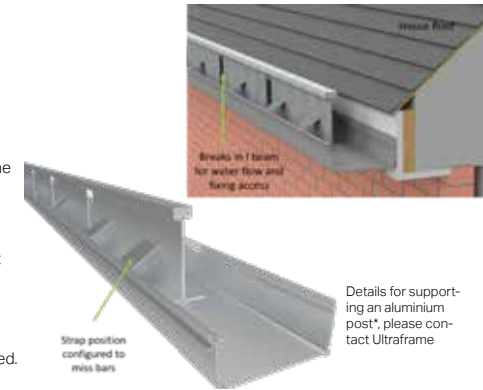

Breakouts in I beam for water flow and fixing access

Strap position configured to miss bars

Details for supporting an aluminium post*, please contact Ultraframe

SUPPORT SPECIFICATION

It is vital when box gutters are specified that - even at sales stage - the issue of providing adequate support is considered. Attachment to timber fascias alone is NOT sufficient and brick piers, gallows brackets and other hangers must be considered.

Injection moulded adapters are used to ensure seamless and watertight jointing between the PVCu gutter and the aluminium box gutter.

Each adapter comes complete with its own dry jointing gasket and measured 'shot' of Gutterbond proprietary sealant to ensure rapid completion even in the inclement weather typically found in the U.K.

All of the box gutters are insulated to minimise condensation risk. Where box gutters are jointed, they are sleeved and bolted.



Custom gallows brackets also available.

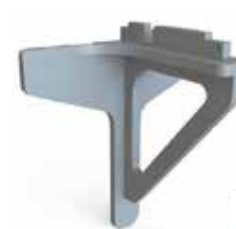

Gallows Bracket - off the shelf. Suitable for 165 or 265 box gutters.



Hanger Bracket - alternative support for 165 box gutters.

OTHER ITEMS - STRUCTURAL

GABLE SUPPORT BEAM

The Gable conservatory is ever more popular as it has a square front to maximise floor space for the homeowner whilst it has an interesting large infill window, into which feature designs like 'sunbursts' can be installed.

When doors are placed beneath a gable frame, additional structural support is needed to ensure frame wobble/deflection is eliminated.

The Gable Support beam interfaces with the standard eaves beam to create one holistic structural 'collar'. It comes complete with 'cheese wedge' infills to ensure neat detailing.

Wendland strongly recommends this upgrade option to be used on gable designs.

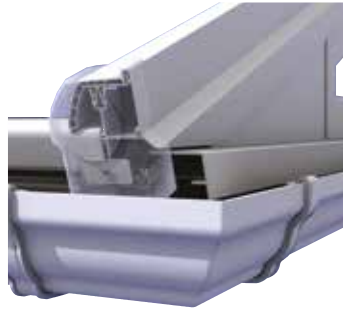
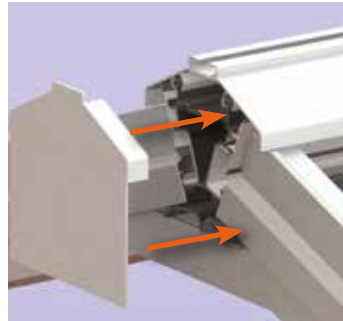

VALLEY

The Valley is a heavy weight structural component that drains two adjacent glazed roof slopes and connects to the eaves beam and the ridge/half ridge.

Glazing bars are fixed to the valley using a sliding bracket that fixes up the centre of the rafter. A tried and tested design capable of varied angles and glazing thickness.



Valleys can be designed / used in the following ways:

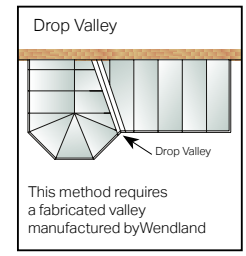
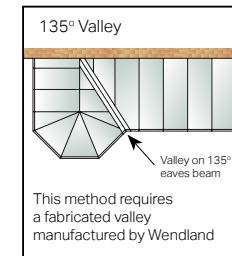
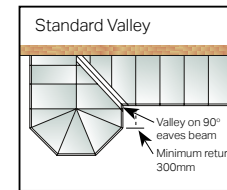

VENTILATION - OPENING ROOF VENTS

Roof Vent can be glazed directly into the ridge (where applicable), the lower muntin is factory sealed to the vent in preparation for on-site glazing. Roof vents can be specified with a pole operated screw jack mechanism or you can opt for a full climate control package of rain sensor and thermostat.

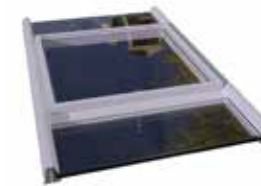

Glass rules

(Calculations for above and below roof vent)

Upper glass unit height = Vent position from upper edge of glass - 10mm.

Lower glass unit height = Overall glass height - upper glass height - vent drop - 20mm.

Vent positioning (measured up the roof pitch)

Minimum of 250mm from ridge centreline

Minimum of 100mm from internal frame line

Colours

The roof vent is available in the colourways below as standard stock items.

External Colours

Caramac (8003)
White (9003)
Deeplas (SC050E 80%)
Brown (8016)

Golden Oak Foil
White
Deeplas
Rosewood Foil



A climate control package is available to automate the roof vent.

CONSERVAFLASH

Conservaflash is a pre-formed PVCu flashing system that will change the way you install.

Conservaflash is an engineered product offering professional results - in a flash! Conservaflash can be specified when a roof is ordered and a pre-configured flashing pack will be delivered with the roof. Conservaflash can be specified when the host wall is of brick construction.

SPECIFICATION

- Stepped Flashing for 15°, 20°, 25°, 30° and 35°.
- Straight Flashing option for lean-tos.
- Save money when compared to buying lead.
- Save at least an hour on each installation.
- No waste - precise amount supplied.
- Comes with the roof - an integrated solution.
- Convenient, pre-packed with no environmental risks.
- Suitable for duo pitch and lean to 'gable to gable' designs

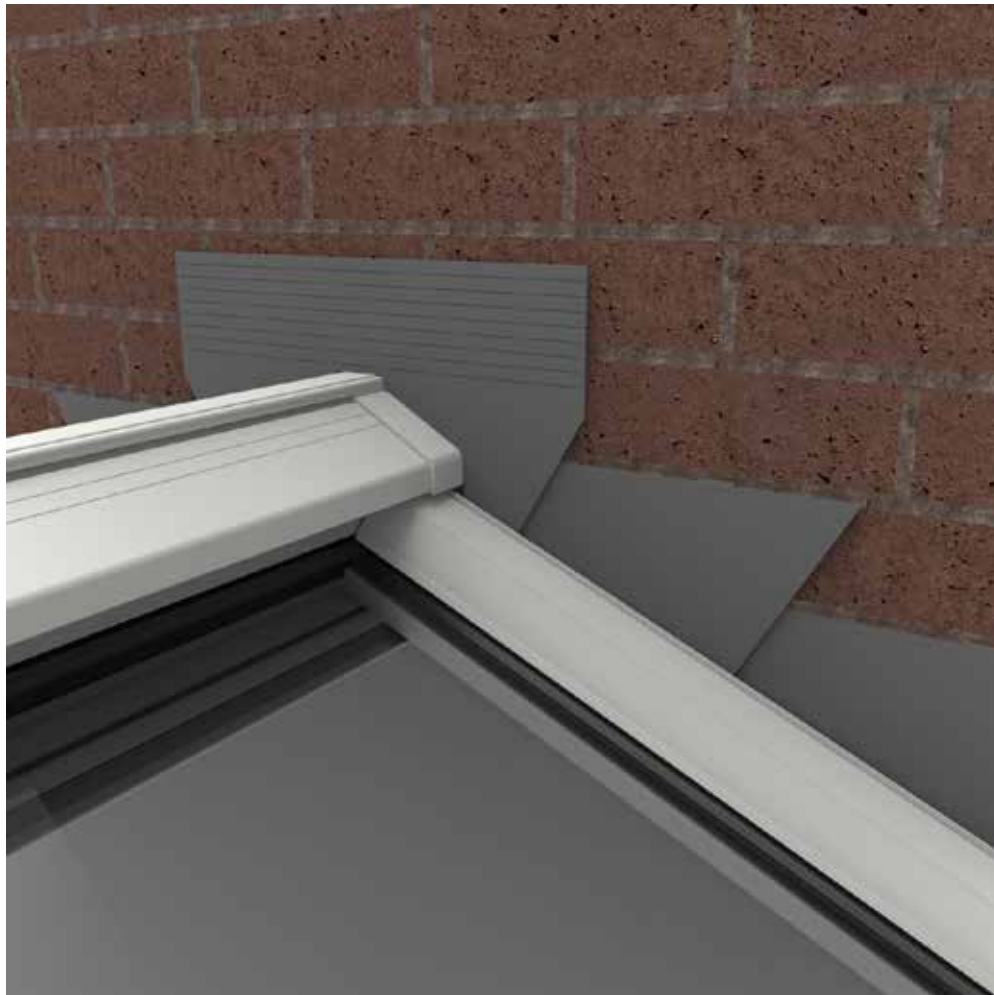

GLAZING AVAILABLE

Wendland roofs are available with glass, polycarbonate or unglazed.

The Conservaglass glazing makes ordering the roof and glass together quick and easy, reducing the number of suppliers.

Conservaglass Range

- Toughened to BS EN 12150-1
- Manufactured to BE EN 1279-2
- 10 year guarantee
- Cleaning
- Cavity Fill
- Warm Edge
- 24mm* (4-16-4)
- Glare reduction *except clear glass options

		Conservaglass										
		Super- Energy Saving Glass							Good Thermal Efficiency			
		Low Solar Gain		Medium Solar Gain			High Solar Gain	Low Solar Gain	Medium Solar Gain		High Solar Gain	
U-Value	Light Transmission	Ultimate Blue	Aqua 45	Bronze 45	Blue 45	Neutral 45	Clear 45	Std Aqua	Std Bronze	Std Blue	Std Neutral	Std Clear
2.0	82%	1.0	1.0	1.0	1.0	1.0	1.0	1.2	1.2	1.2	1.2	1.2
55%	28%	58%	59%	59%	59%	59%	68%	32%	52%	50%	48%	77%
75%	15%	54%	54%	54%	54%	54%	85%	34%	49%	46%	43%	78%
25%	45%	94%	94%	94%	94%	94%	89%	52%	52%	50%	73%	73%
Blue	Aqua	Bronze	Blue	Neutral	Clear	Aqua	Bronze	Blue	Neutral	Clear		

Please Note: Delivery charges may apply.

In order to pass building regulations, all conservatory over 2.5m wide will need a glass U-value of at least 1.2. Smaller conservatories will need glass to be specified with 1.0 U-value. The thermal design guide will provide the specific U-Value of each glass roof.

POLYCARBONATE

Polycarbonate Sheet	Light Transmission		Solar Transmission		U Value W/m ² K ⁻¹		Shading Efficiency	
Size	25mm	32mm	25mm	32mm	25mm	32mm	25mm	32mm
Clear	65%	51%	63%	55%	1.7	1.3	73%	72%
Opal	31%	29%	37%	35%	1.7	1.3	42%	41%
Bronze	24%	11%	26%	14%	1.7	1.3	30%	27%
Bronze / Opal	11%	18%	16%	22%	1.7	1.3	18%	17%
Solarguard	5%	8%	8%	8%	1.7	1.3	9%	9%

Light Transmission - Percentage of light transmitted through the unit / polycarbonate sheet.

Solar Rejection - The proportion of the sun's energy that is rejected. The higher the percentage the better it is.

Solar Transmission - The proportion of the sun's energy that is transmitted through the sheet. The lower the percentage the better it is.

U Value W/m² °K - A measure of how good the material is at preventing heat loss to the outside. The lower the figure, the more thermally efficient it is.

UV Protection - The higher the % the lower the possibility of furniture and fabrics fading.#

Shading Efficiency - The lower the figure the more shade is created.

GLASS STOPS

Whether polycarbonate or glass units, glass stops are automatically supplied to top glass from slipping. Robust moulded glazing stops that simply screw down through the glazing bar, align with the end of the bar for a simple set out.

- No jig's or pre-drilled holes required
- Easily adjustable
- Purpose design glazing stops
- Glass fully supported on hips and splays
- No notching required

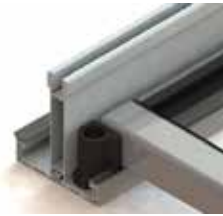

COLOURS / FINISHES - PVCu ROOFS

For a glass roof, choose from a range of colours – these can be different inside and out. The roofs are available in White, deepplac, rosewood, golden oak and grey as standard or any RAL colour available on request.



COLOURED FOILED PRODUCT CHART

Item	Supplied Foiled*	Moulded/Extruded in base colour (or painted/ powder coated)
Glazing Bar	Top Cappings Internal Claddings Bolster Covers Lean-to Cloaking Trim Muntin Bars Glazing End Channel	End caps moulded colour or painted.
Eaves Beam	Internal Cladding (7560) I	Glazing Support Trim - Extruded to internal colour. Glazing Support Trim - Extruded black on grey roofs. Internal Fascia Corners - moulded or painted. Under Gutter Trim - Cream/white on cream/white roofs & black on other colours)
Ridge	Undercladding Internal Half Ridge Undercladding Low Pitch Wallplate Internal Wallplate External	Finial moulded colour or painted. Low Profile endcap painted or powder coated. Low Profile Cresting painted or powder coated. Cresting moulded colour or painted. External Half Ridge Capping extruded base colour or painted. Half Ridge & Full Ridge External Crown covers moulded colour or painted. Full & Half Ridge and Wallplate End Caps moulded colour or painted. Gable End Cappings extruded base colour or foiled.
Gutter	N/A	Cream/white Marley Classic gutter extruded base on cream/white roofs. Extruded base colour for Rosewood or Golden Oak roofs. Black** Marley Classic Gutter on other standard. Coloured painted Marley Classic Gutter (Supplied at additional cost).
Valleys	Internal Claddings	External Cladding extruded or painted.
Roof Vents	Rosewood, Golden Oak and Anthracite flat matt are foiled onto black profile	Painted. Motors are white on white roofs and black on other coloured roofs.
Box Gutter	Undercladding	Multiboard - Raised Back Box Gutters. Foiled or painted. Adaptors moulded to match gutter or painted.

Specification / notes

Single skin top cappings supplied as standard (cream or white only). Chambered optional.

On ridges, choose from low profile or cresting and finial.

A chrome tie bar is specified on internally coloured roofs. Cream/white tie bars are used on cream/white roofs.

A coloured conservatory consists of foiled and painted parts. Every effort is made to ensure gloss levels are within reasonable tolerance. RAL and BS colour references are made in good faith - always give a sample swatch to your supplier when ordering any other parts (frames, cills etc) to match.

A coloured conservatory consists of foiled and painted parts. Every effort is made to ensure gloss levels are within reasonable tolerance. RAL and BS colour references are made in good faith - always give a sample swatch to your supplier when ordering any other parts (frames, cills etc) to match.

INTERNAL PELMET

The internal pelmet is formed from a steel ladder framework and creates a room-like look. It also boosts the thermal performance and provides a space for lights or cables. The internal pelmet allows you to enjoy the natural light of a conservatory, but also gives a feel of being in an extension.

- Can be used from 5° to 40°
- Steelwork ladder system extends from 300mm to 1200mm
- Up to 40% lower heating costs
- Datum point is internal side frame to external face of 12.5mm plasterboard
- Suitable to use with bi-folds and French doors
- Available across a wide range of styles: Victorian, Georgian, Gable and Lean-to
- Orangery style internal pelmet is the perfect place for spotlights, speakers and cable runs.



GUTTER COVER

The gutter cover covers the gutter, hiding the ends of the glazing bars. This can be added as an upgrade to new conservatories or retro-fitted to existing roofs. The gutter cover adds style by hiding the ends of the glazing bars and giving a new, more ornate look at the eaves.

- Gutter cover can be used to give a new look to on the outside at the eaves
- Can be used with Wendland glass roof, Livinroof and Ultrarroof.
- Gutter cover for 135° and 90° corners now featured as standard
- Makes the roof/frames border look neater - hiding glazing bar end caps, gutter/brackets and the ends of the glazing panels
- Perfectly matches the colour of the windows and doors
- Blends with the design of your choice, no matter what the style of windows and doors e.g. bi-folds





www.Wendland.uk.com

© Wendland - Our policy is one of continuous improvement and we reserve the right to change specification and design at any time without prior notice

Job No. 7002 WENDLAND tech guide 08/24